

JANAM

XT3 Series™

Quick Start Guide

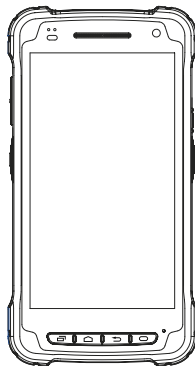

Technology at Work.®

XT3 Series Quick Start Guide

Copyright 2019 Janam Technologies LLC. All rights reserved.

XT3 Series, Janam and the Janam logo are trademarks of Janam Technologies LLC. Other product and brand names may be trademarks or registered trademarks of their respective owners.

Janam Technologies LLC assumes no responsibility for any damage or loss resulting from the use of this guide. Janam Technologies LLC assumes no responsibility for any loss or claims by third parties which may arise through the use of this product. Janam Technologies LLC assumes no responsibility for any damage or loss caused by deletion of data as a result of malfunction, dead battery or repairs. To protect against data loss, be sure to make backup copies (on other media) of all important data.

Follow all usage, charging and maintenance guidelines in the Product User Guide. If you have questions, contact Janam. For a copy of the Product User Guide, visit www.janam.com.

Important: Please read the End User License Agreement for this product before using the device or the accompanying software program(s). Using the device or any part of the software indicates that you accept the terms of the End User License Agreement.

Content and Additional Resources

To help you get started with your XT3 Series mobile computer, this guide features:

- Hardware Overview
- Getting Started
 - A. Install the Battery
 - B. Charge the Battery
 - C. Remove the Battery + Access Card Slot
- Battery Warnings and Safety Guidelines

Contents of this guide are subject to change.

For software updates and information, visit www.android.com.

Hardware Overview

1. Power key
2. 3.5mm headset jack
3. Touch screen
4. Front camera
5. Barcode scanner
6. LED indicator
7. Illuminance sensor indicator
8. Volume key
9. Left trigger
10. Home key
11. Recent apps key
12. USB-C port
13. I/O sync connector
14. Back key
15. Programmable key
16. Microphone
17. Right trigger

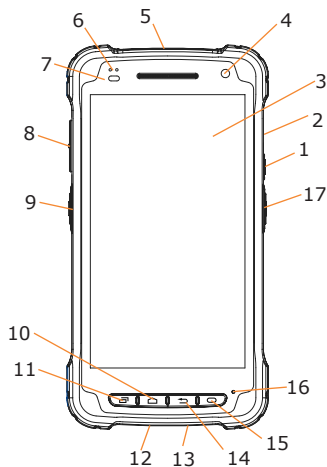

Hardware Overview

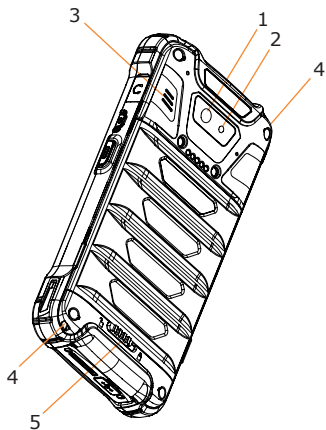

1. Camera
2. Camera flash
3. Speaker
4. Lanyard hole
5. Battery cover lock

Getting Started

Important Note: The main (removable) battery charges the internal backup battery with or without an external power source. When discharged, the backup battery requires approx. 1.5 hours to recharge.

Caution: All user data will be lost if the main battery is removed before the internal backup battery is properly charged. It is recommended you check that the backup battery capacity is at 100% prior to removing the main battery. To do this, access Settings-> Battery. It is also recommended that you first suspend the device prior to removing the main battery.

A. INSTALL THE BATTERY

1. Place the battery with the label side facing down.
2. Slide the battery into the compartment.
3. Firmly push the battery into place.

B. CHARGE THE BATTERY

To charge the battery using the **USB Cable:**

1. Connect the power supply to the USB cable.
2. Connect USB cable to USB-C port.
3. Plug in the power supply. Use only easily accessible wall outlets that are easily reached with the length of supplied power cable.

To charge the battery using a **Cradle Kit:**

1. Connect the power supply to the cradle.
2. Plug in the power supply. Use only easily accessible wall sockets that are easily reached with the length of supplied power cable.
3. Place the device in cradle. The LED on the device will illuminate to confirm connection.
4. The standard capacity battery is fully charged in approx. 4 hours.
5. To charge a battery in the spare battery well, insert the battery into the well **top down** and gently press down. The LED light on the cradle will illuminate to confirm connection.

Getting Started (continued)

C. REMOVE THE BATTERY + ACCESS CARD SLOT

1. Slide the battery door lock switch until it is open.



2. Remove the battery by lifting it up.



3. SIM / SAM / MicroSD card slot is now accessible in upper part of housing.

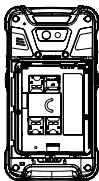

Battery Warning

CAUTION

**IF MISUSED OR MISTREATED THE BATTERY MAY PRESENT A RISK OF FIRE OR CHEMICAL BURN.
RISK OF EXPLOSION IF BATTERY IS REPLACED BY AN INCORRECT TYPE.
DISPOSE OF USED BATTERIES ACCORDING TO THE INSTRUCTIONS.**

ATTENTION

**Un remplacement inadéquat de la batterie ou une utilisation incompatible de l'appareil peut présenter des risques de brûlures, d'incendie, d'explosion ou d'autres dangers.
Jetez les piles en lithium-ion conformément aux réglementations locales.**

BATTERY SAFETY GUIDELINES.

Use only Janam XT3 Series batteries and recharge batteries using only Janam approved charging accessories. Observe the following guidelines for safe use of Li-Ion batteries:

1. Do not expose the battery to excessive heat or cold. Do not short-circuit. Do not incinerate.
2. To avoid risk of fire, burn or damage to your battery, do not allow a metal object to touch battery contacts.
3. Do not disassemble the battery. There are no user serviceable parts inside.
4. If battery leakage is observed, avoid any contact with affected area and properly dispose of the battery.
5. If you come in contact with battery leakage, rinse exposed area with soap and water. If it contacts the eye, flush the eye with water for 15 minutes and seek medical attention.
6. Dispose of used battery promptly. Keep away from children. Do not disassemble or dispose of in fire.
7. When discarding a battery, contact your local waste disposal provider to understand local restrictions for disposal or recycling of batteries.

BATTERY CHARGER SAFETY GUIDELINES.

1. Do not use the equipment in or near areas in which sparks are likely or possible.
2. Do not let equipment's metal contacts and electrical sockets come in contact with metal objects.
3. For indoor use only. Do not expose the equipment to rain or any liquids.
4. Do not use or store the equipment in direct sunlight or in areas that are prone to get hot such as in a parked vehicle, near a heat duct or close to other heat sources.
5. Keep equipment's metal contacts and electrical sockets free from debris that could obstruct charging or could cause a short circuit.

Regulatory



www.sar-tick.com

Body-worn Operation

This device was tested for typical bodyworn operations with the Front & back of the device kept 0.59 inches (1.5cm) between the user's body and the Front & back of the device. To comply with FCC RF exposure requirements, a minimum separation distance of 0.59 inches (1.5cm) must be maintained between the user's body and the Front & back of the device. Any beltclips, holsters, and similar accessories containing metallic components may not be used. Body-worn accessories that cannot maintain 0.59 inches (1.5cm) separation distance between the user's body and the Front & back of the device, and have not been tested for typical body-worn operations may not comply with FCC RF exposure limits and should be avoided.

FCC Warning

This device complies with part 15 of the FCC Rules. Operation is subject to the following two conditions: (1) This device may not cause harmful interference, and (2) this device must accept any interference received, including interference that may cause undesired operation.

This equipment has been tested and found to comply with the limits for a Class B digital device, pursuant to part 15 of the FCC Rules. These limits are designed to provide reasonable protection against harmful interference in a residential installation. This equipment generates, uses and can radiate radio frequency energy and, if not installed and used in accordance with the instructions, may cause harmful interference to radio communications. However, there is no guarantee that interference will not occur in a particular installation. If this equipment does cause harmful interference to radio or television reception, which can be determined by turning the equipment off and on, the user is encouraged to try to correct the interference by one or more of the following measures:

- Reorient or relocate the receiving antenna.
- Increase the separation between the equipment and receiver.
- Connect the equipment into an outlet on a circuit different from that to which the receiver is connected.
- Consult the dealer or an experienced radio/TV technician for help.

Caution: Any changes or modifications to this device not expressly approved by the party responsible for compliance could void your authority to operate the equipment.

Regulatory

IC Warning

This device complies with Industry Canada license-exempt RSS standard(s). Operation is subject to the following two conditions: (1) This device may not cause interference; and (2) This device must accept any interference, including interference that may cause undesired operation of the device.

Le présent appareil est conforme aux CNR d'Industrie Canada applicables aux appareils radio exempts de licence. L'exploitation est autorisée aux deux conditions suivantes : (1) l'appareil ne doit pas produire de brouillage, et (2) l'utilisateur de l'appareil doit accepter tout brouillage radioélectrique subi, même si le brouillage est susceptible d'en compromettre le fonctionnement.

This device is restricted to indoor use only within the 5.15 ~ 5.35GHz Band.

Cet appareil est restreint à l'utilisation à l'intérieur seulement dans la bande 5.15 ~ 5.35GHz.

This equipment complies with FCC/IC radiation exposure limits set forth for an uncontrolled environment. This transmitter must not be collocated or operating in conjunction with any other antenna or transmitter unless authorized to do so by the FCC/IC.

Cet équipement est conforme aux limites d'exposition aux radiations FCC / IC définies pour un environnement non contrôlé. Cet émetteur ne doit pas être colocalisé ou fonctionner en conjonction avec une autre antenne ou un autre émetteur, à moins d'être autorisé à le faire par le FCC / IC.

Laser Warning

- LASER LIGHT. DO NOT STARE INTO BEAM. CLASS 2 LASER PRODUCT. 1.0 mW MAX OUTPUT 650 nm. (LUMIERE LASER, NE PAS REGARDER DIRECTEMENT DANS LE FAISCEAU, PRODUIT LASER DE CLASSE 2, SORTIE MAX. DE 1,0 MW: 650 nm.)
- Complies With 21CFR 1040.10 and 1040.11 except for deviations pursuant to Laser Notice No.50 dated June 24 2007. (Cet appareil a été testé et reconnu conforme aux normes 21 CFR 1040.10 et 1040.11 sauf pour les dérogations en accord avec l'avis de conformité sur les lasers No. 50, en date du 24 juin 2007.)

E-label

Users can access to the product certificate information in Settings -> About phone -> Certificates.

WCDMA/LTE feature is optional. Some product options only include WLAN feature.

FCC ID : UTWXT3WC (PHONE), UTWXT3WD (WLAN)

IC ID : 6914A-XT3WC (PHONE), 6914A-XT3WD (WLAN)